

Bourdon tube pressure gauge

All stainless-steel construction

(50mm, 63mm)



Features:

- All SS case
- All SS Measuring System
- Dry / Liquid filled

Applications:

- Pumps
- Engine Compressors
- Turbines
- Conventional & Nuclear Plants
- Chemical & Petrochemical Industries
- Food & Beverage
- Pharmaceutical
- Cryogenics
- Presses

Standard:

- EN 837-1 (NS 50mm,63mm)

Standard Parameters

Accuracy	: ±1.6% of F. S. (for NS 63mm), ±2.5% F.S. (for NS 50mm)
Ambient temperature	: -20 to +65°C
Process temperature	: Max 200°C
Operating Pressure Range	: 75% of the scale value
Over Pressure Limit	: ≤ 100 bar : 125% of Max. Scale Value : > 100 to ≤ 600 bar : 115% of Max. Scale Value : > 600 to ≤ 1600 bar : 110% of Max Scale Value

Materials of Construction

Case & bezel	: AISI 304 SS (Bayonet type)
Bourdon	: AISI 316L SS
Socket	: AISI 316 SS (Directly welded to case)
Movement	: AISI 304 SS
Joints	: Tig Argon Arc Welding
Protection	: IP 65
Dial	: Aluminium, black graduation on white background
Pointer	: Black coloured, fixed
Window	: Plexi glass
Filling Plug	: Nitrile
Gasket	: Neoprene

Glycerine Filled Version

Accuracy	: ±1.6% of F.S. (63mm), ±2.5% of F.S. (50mm)
Ambient & Process Temperature	: Maximum 65°C
Window	: Plexi Glass
Dampening Liquids	: Glycerine 99.7%

Temperature Effect

The variation of indication caused by effects of temperature is to be calculated by below formula which is to be added in the specific accuracy while measurement:

Formula $\pm 0.04 \times (t_2 - 1) \%$ of F.S.

where t1: reference temperature (+20°C) and t2: ambient temperature in °C.

Bourdon tube pressure gauge

All stainless-steel construction (50mm, 63mm)

SP

Dimensional drawing

TYPE 1

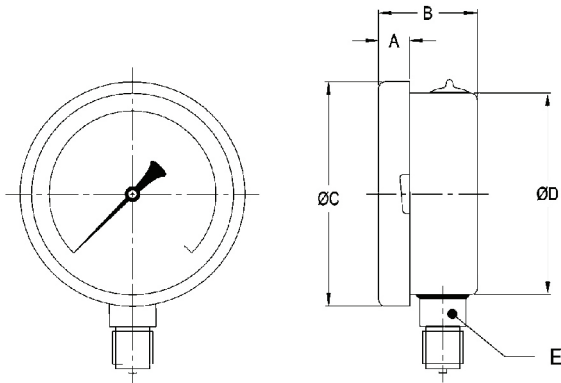

TYPE 2

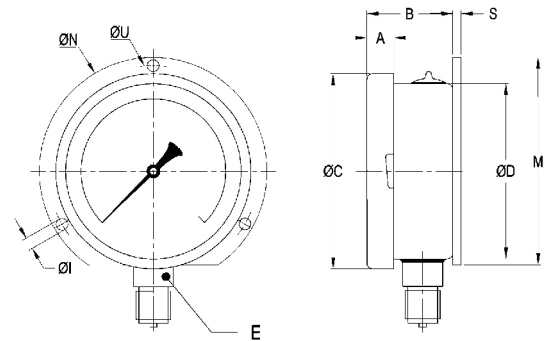

NS	A	B	ØC	ØD	E	W	WG
50	11	32.5	58.5	51	14	153	210
63	11	32	69.5	62.5	14	180	240

W = Weight in grams with box
WG = Weight in grams with glycerine & box

NS	A	B	ØC	ØD	E	M	S	ØI	ØN	ØU	W	WG
63	11	32	69.5	62.5	14	80	7	3.6	86	75	720	1025

W = Weight in grams with box
WG = Weight in grams with glycerine & box

TYPE 4

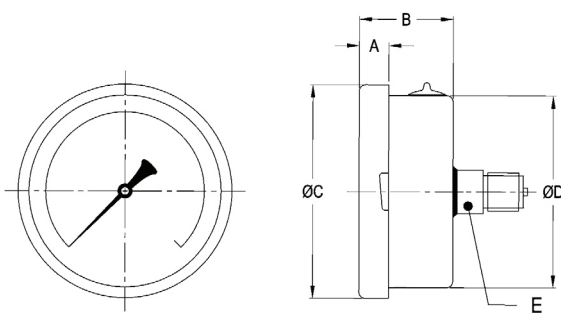

TYPE 5

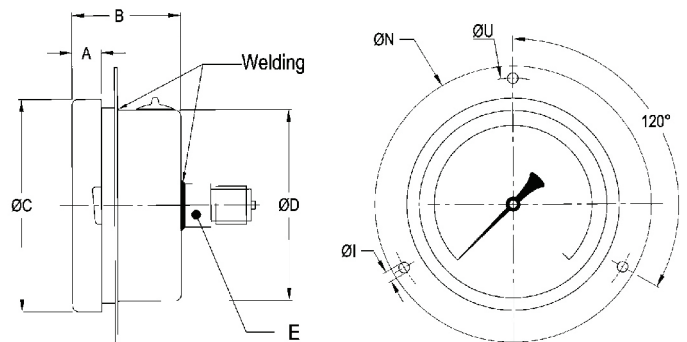

NS	A	B	ØC	ØD	E	W	WG
50	11	32.5	58.5	51	14	170	230
63	11	32	69.5	62.5	14	188	250

W = Weight in grams with box
WG = Weight in grams with glycerine & box

NS	A	B	ØC	ØD	E	ØN	ØI	ØU	W	WG
63	11	32	69.5	62.5	14	86	3.6	75	213	275

W = Weight in grams with box
WG = Weight in grams with glycerine & box

Note: ● Drawings are not to scale ● All dimensions are in mm

Dimensional drawing - Rolling type

TYPE 1

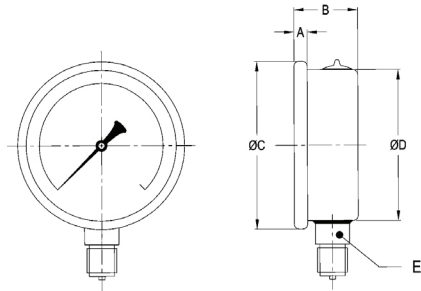

NS	A	B	ØC	ØD	E	W	WG
100	12.5	45	111	100	22	695	990
125	15	46	129	119	22	850	1170

W = Weight in grams with box
WG = Weight in grams with glycerine & box

TYPE 2

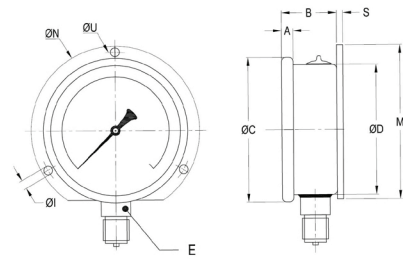

NS	A	B	ØC	ØD	E	S	ØI	ØN	ØU	M	W	WG
63	6.5	30.5	69	62.5	14	7	3.6	86	75	80	190	250

W = Weight in grams with box
WG = Weight in grams with glycerine & box

TYPE 4

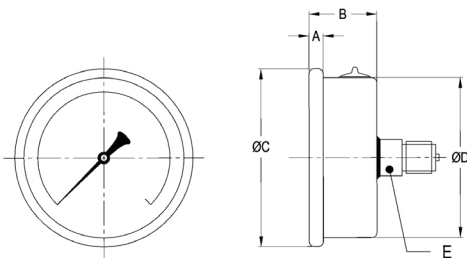

NS	A	B	ØC	ØD	E	W	WG
50	4.5	29	57.5	51.5	14	117	167
63	6.5	30.5	69	62.5	14	170	230

W = Weight in grams with box
WG = Weight in grams with glycerine & box

TYPE 5

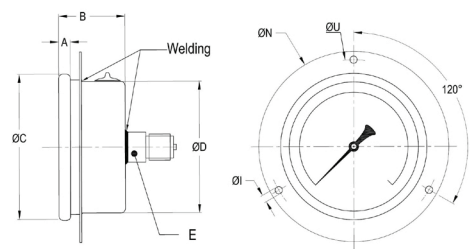

NS	A	B	ØC	ØD	E	ØN	ØI	ØU	W	WG
63	6.5	30.5	69	62.5	14	86	3.6	75	170	230

W = Weight in grams with box
WG = Weight in grams with glycerine & box

TYPE 10

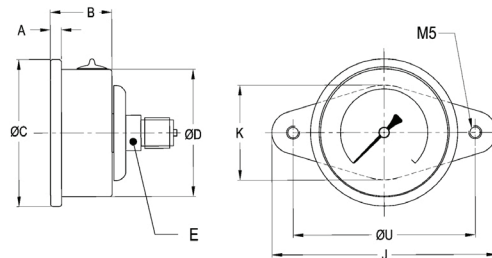

NS	A	B	ØC	ØD	E	J	K	ØU	W	WG
50	5	29	57	51.5	14	91	38	70.5	180	240
63	6.5	30.5	69	62.5	14	91	38	70.5	210	270

W = Weight in grams with box
WG = Weight in grams with glycerine & box

Note: ● Drawings are not to scale ● All dimensions are in mm

Bourdon tube pressure gauge

All stainless-steel construction (50mm, 63mm)

SP

Range table

Note: We offer Pressure, Vacuum and Compound ranges in Scales like kPa, MPa, bar, psi, kg/cm² & dual Scale like kPa with psi, kPa with bar, bar with psi or scales as per the requirement can be provided on request. Following are the example tables for kg/cm² & psi scales

Pressure Table

Dual scale (psi with Kg/cm²)

psi	kg/cm ²	psi	kg/cm ²	psi	kg/cm ²
0/15	0/1	0/400	0/28	0/4000	0/280
0/30	0/2	0/500	0/35	0/5000	0/350
0/60	0/4	0/600	0/40	0/6000	0/420
0/100	0/7	0/1000	0/70	0/10000♣	0/700♣
0/150	0/10	0/1500	0/100	0/15000♣	0/1000♣
0/220	0/16	0/2200	0/160		
0/300	0/20	0/3000	0/200		

♣Applicable for NS 63mm only

Vacuum and Compound Range (for NS 63mm only)

inHg with psi	kg/cm ²	inHg with psi	kg/cm ²
- 30/30	- 1/2	- 30/150	- 1/10
- 30/60	- 1/4	- 30/200	- 1/14
- 30/100	- 1/7	- 30/300	- 1/ 21

Ammonia with temperature scale (for NS 63mm only)

Range (kg/cm ²)	Range (psi)
-1 to 12.5	-30 - 150
-1 to 16	-30 - 300
-1 to 25	0 - 300

Accessories

Cooling Tower	Overload Protector (Gauge Saver)	Snubber
Gauge Cock	Needle Valve	Siphon

Ordering codes

1. Dial Size		C	5. Window		PG
Code	Nominal size		PG	Plexi glass	
B	50mm	1	SG	Shatterproof/safety glass	BY
C	63mm		TG	Toughened glass	
2. Mounting			6. Bezel Type		5C
1	Direct bottom		BY	Bayonet (Standard)	
2	Bottom surface◆		R	Rolling	
4	Direct center back entry		7. Options		0-10 Kg/cm²
5	Flush back panel with front flange◆		S6	AISI 316 SS case & bezel	
10	Centre back entry with mounting bracket*		5C	Five-point calibration certificate	
◆Applicable for NS 63mm only			OS	Oxygen service (for dry version)	
*Applicable for rolling type design only			MP	Maximum reading pointer with plexi glass# (except option OA and only for dry version)	
3. Gauge Connection		DS	Dampening screw in AISI 316 SS		
3B	1/8" BSP[M]	ST	SS tag plate		
3N	1/8" NPT[M]	CD	Custom designed dial		
3BT	1/8" BSPT[M]	FR	Freon range (with temperature scale)		
06B	1/4" BSP[M]	AR	Ammonia range (with temperature scale)		
06N	1/4" NPT[M]	I5	Enclosure protection IP 65		
06BT	1/4" BSPT[M]	I8	Enclosure protection IP 68		
4. Execution		MT	Material test certificate**		
DR	Dry	HL	Helium leak test		
FL	Fillable Liquid	NT	Calibration certificate with NABL traceability		
LG	Liquid Glycerine	5. Range			
LS	Liquid Silicon	Refer range table			

Ordering Example: SP-C-1-06B-DR-PG-BY-5C-0-10Kg/cm²

**Material test certificate will be provided for wetted parts only. For others, pls contact factory.

For NS 63mm only

Note: Specifications and dimensions given in this product catalogue represents the state of engineering at the time of printing. Modifications may take place and materials specified may be replaced by others without prior notice.