

Bourdon tube pressure gauge

All stainless-steel construction



Features:

- All SS Case
- All SS Measuring System
- Dry / Liquid filled
- CE Marking (for NS 100mm & 150mm)

Applications:

- Pumps
- Engine Compressors
- Turbines
- Conventional & Nuclear Plants
- Chemical & Petrochemical Industries
- Food & Beverage
- Pharmaceutical
- Cryogenics
- Presses

Standard:

- EN 837-1 (NS 100,150,200,250)
- IS-3624-2001 (NS 100)

Standard Parameters

Accuracy	: ±1.0% of F. S.
Ambient temperature	: -20 to +65°C
Process temperature	: 300°C max.
Operating Pressure Range	: 75% of the scale value
Over Pressure Limit	: ≤ 100 bar : 125% of Max. Scale Value
	: > 100 to ≤ 600 bar : 115% of Max. Scale Value
	: > 600 to ≤ 1600 bar : 110% of Max Scale Value

Materials of Construction

Case & bezel	: AISI 304 SS
Bourdon	: AISI 316L SS
Socket	: AISI 316 SS (Directly welded to the case)
Movement	: AISI 304 SS
Joints	: Tig Argon Arc Welding
Protection	: IP 65
Dial	: Aluminium, black graduation on white background
Pointer	: Aluminium, black coloured, slotted zero adjustable
Window	: Sheet glass
Filling Plug	: Neoprene
Gasket	: Neoprene

Glycerine Filled Version

Accuracy	: ±1.6% of F.S.
Ambient & Process Temperature	: Maximum 65°C
Window	: Plexi Glass
Dampening Liquids	: Glycerine 99.7%

Temperature Effect

The variation of indication caused by effects of temperature is to be calculated by below formula which is to be added in the specific accuracy while measurement:

Formula $\pm 0.04 \times (t_2 - 1) \% \text{ of F.S.}$

where t1: reference temperature (+20°C) and t2: ambient temperature in °C.

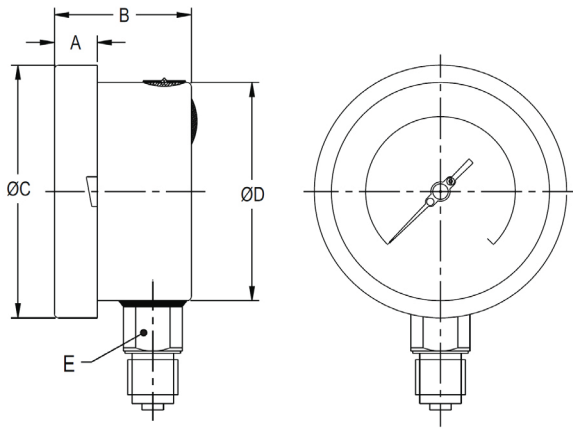
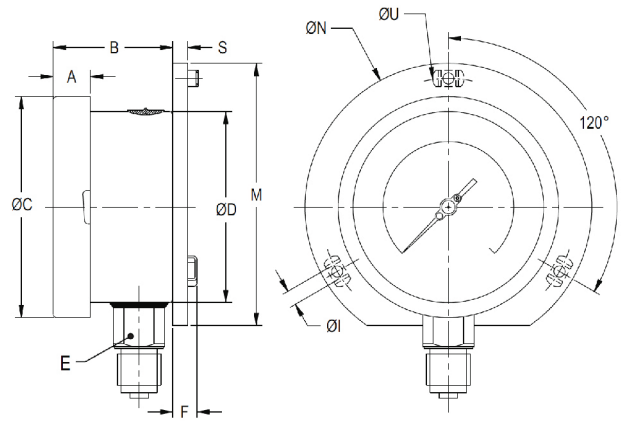
Dimensional drawing
TYPE 1

TYPE 2

NS	A	B	ØC	ØD	E	W	WG
100	12.5	45	111	100	22	720	1025
125	15	46	129	119	22	845	1165
150	15	46.5	161	149	22	1160	1895
200	18	49	216.5	201.5	22	2020	2780
250	18	52	263	250	22	2400	3220

W = Weight in grams with box
WG = Weight in grams with glycerine & box

NS	A	B	ØC	ØD	E	M	S	F	ØI	ØN	ØU	W	WG
100	12.5	45	111	100	22	128	6	14.5	6	134	118	720	1025
125	15	46	129	119	22	143	4	14.5	6	150	137	845	1165
150	15	46.5	161	149	22	174.5	6	14.5	6	186	168	1160	1895
200	18	49	216.5	201.5	22	229	1.5	14.5	7	245	230	2020	2780
250	18	52	263	250	22	286.5	1.5	14.5	7	290	276	2400	3220

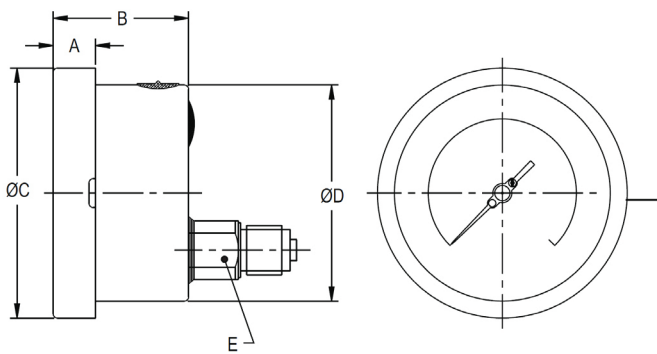
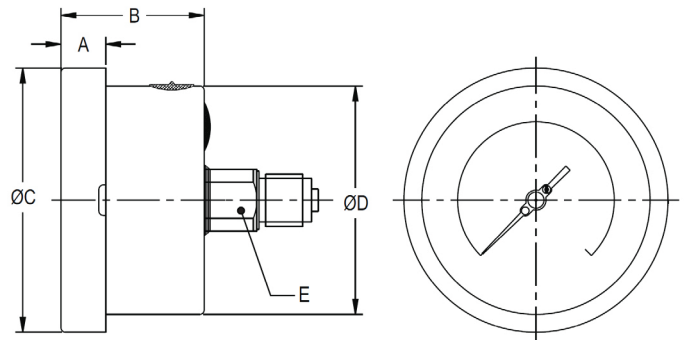
W = Weight in grams with box
WG = Weight in grams with glycerine & box

TYPE 3

TYPE 4

NS	A	B	ØC	ØD	E	W	WG
100	12.5	47	111	100	22	640	935
125	15	48	129	119	22	750	1070
150	15	49	161	149	22	1000	1735
200	18	49	216.5	201.5	22	1500	2260
250	18	52	263	250	22	1800	2620

W = Weight in grams with box
WG = Weight in grams with glycerine & box

NS	A	B	ØC	ØD	E	W	WG
100	12.5	47	111	100	22	640	935

W = Weight in grams with box
WG = Weight in grams with glycerine & box

Note: ● Drawings are not to scale ● All dimensions are in mm

Dimensional drawing

TYPE 5

TYPE 6

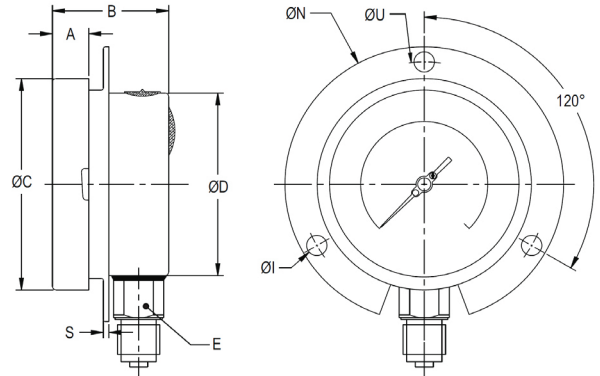
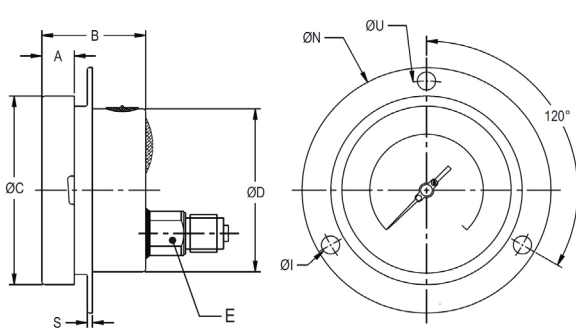

NS	A	B	ØC	ØD	E	S	ØI	ØN	ØU	W	WG
100	12.5	45	111	100	22	1	6	134	118	695	990
125	15	46	129	119	22	1	6	150	137	850	1170
150	15	46.5	161	149	22	1	6	186	168	1100	1835
200	18	49	216.5	201.5	22	1.5	7	245	230	2000	2760
250	18	52	263	250	22	1.5	7	290	276	2250	3070

W = Weight in grams with box
 WG = Weight in grams with glycerine & box

NS	A	B	ØC	ØD	E	S	ØI	ØN	ØU	W	WG
100	12.5	47	111	100	22	1	6	134	118	730	1025
125	15	48	129	119	22	4	6	150	137	815	1135
150	15	49	161	149	22	5	6	186	168	1100	1835

W = Weight in grams with box
 WG = Weight in grams with glycerine & box

TYPE 8

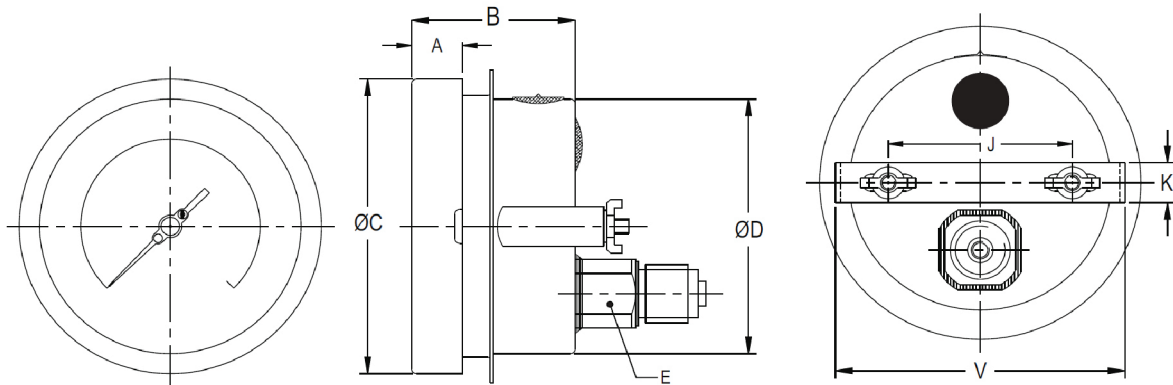

NS	A	B	ØC	ØD	E	J	K	V	W	WG
100	12.5	47	111	100	22	72	16	108	740	1035
125	15	48	129	119	22	75	16	125	890	1210
150	15	49	161	149	22	106.5	16	166	1100	1835
200	18	49	210.5	201.5	22	165	16	208	1920	2680
250	18	52	263	250	22	180	30	270	2300	3120

W = Weight in grams with box
 WG = Weight in grams with glycerine & box

Note: ● Drawings are not to scale ● All dimensions are in mm

Range table

Note: We offer Pressure, Vacuum and Compound ranges in Scales like kPa, MPa, bar, psi, kg/cm² & dual Scale like kPa with psi, kPa with bar, bar with psi or scales as per the requirement can be provided on request. Following are the example tables for kg/cm² & psi scales

Pressure Table

Single scale with Kg/cm²

0/0.6	0/4	0/25	0/160	0/1000
0/1	0/6	0/40	0/250	0/1600
0/1.6	0/10	0/60	0/400	
0/2.5	0/16	0/100	0/600	

Dual scale (psi with Kg/cm²)

psi	kg/cm ²	psi	kg/cm ²	psi	kg/cm ²
0/15	0/1	0/400	0/28	0/4000	0/280
0/30	0/2	0/500	0/35	0/5000	0/350
0/60	0/4	0/600	0/40	0/6000	0/420
0/100	0/7	0/1000	0/70	0/10000	0/700
0/150	0/10	0/1500	0/100	0/15000	0/1000
0/220	0/16	0/2200	0/160	0/22000	0/1600
0/300	0/20	0/3000	0/200		

Vacuum and Compound Range

Dual scale

inHg with psi	mmHg with kg/cm ²	inHg with psi	mmHg with kg/cm ²	inHg with psi	mmHg with kg/cm ²
- 30/0	- 760 / 0	- 30/60	- 760 / 4	- 30/200	- 760 / 14
- 30/15	- 760 / 1	- 30/100	- 760 / 7	- 30/300	- 760 / 21
- 30/30	- 760 / 2	- 30/150	- 760 / 10	- 30/350	- 760 / 25

Single scale Kg/cm²

- 1/0	-1/1.5	- 1/5	- 1/15
- 1/0.6	-1/3	- 1/9	- 1/24

Freon (with temperature scale)

Ammonia (with temperature scale)

Range (psi)		Range (kg/cm ²)	Range (psi)
-30 in Hg - 150	0-300	-1 to 12.5	-30 - 150
-30 in Hg - 300	0-500	-1 to 16	-30 - 300
		-1 to 25	0 - 300

Accessories

Cooling Tower	Overload Protector (Gauge Saver)	Snubber
Gauge Cock	Needle Valve	Siphon

Ordering codes

1. Dial Size		E	5. Window		SG	
Code	Nominal size		PG	Plexi glass		
E	100mm		SG	Shatterproof/safety glass		
F	125mm	1	TG	Toughened glass	BY	
G	150mm		6. Bezel Type			
H	200mm		BY	Bayonet (Standard)		
I	250mm		R	Rolling		
2. Mounting			10B	7. Options		5C
1	Direct bottom			OA	Accuracy ± 0.5% of F.S. (for dry version)	
2	Bottom surface			S6	AISI 316 SS case & bezel	
3	Direct lower back entry			SD	AISI 316 SS movement	
4	Direct center back entry			5C	Five-point calibration certificate	
5	Flush back panel with front flange			OS	Oxygen service (for dry version)	
6	Bottom entry with front flange	KP		Knife edge pointer		
7	2" pipe/yoke mounting*	MP		Maximum reading pointer with plexi glass♦ (except option OA and only for dry version)		
8	Back entry with mounting bracket	DS		Dampening screw in AISI 316 SS		
*Ask factory if drawing required		DR		EA	External zero adjustment	
3. Gauge Connection			ST	SS tag plate		
06B	1/4" BSP[M]		DT	Dial tag marking		
10B	3/8" BSP[M] standard		CD	Custom designed dial		
15B	1/2" BSP[M] standard		RR	Receiver range		
06N	1/4" NPT[M]		FR	Freon range (with temperature scale)		
10N	3/8" NPT[M]		AR	Ammonia range (with temperature scale)		
15N	1/2" NPT[M] standard		EP	Electro polished case & bezel		
06BT	1/4" BSPT[M]		FP	Fixed pointer		
10BT	3/8" BSPT[M]		OP	Over range protection 150% F.S.		
15BT	1/2" BSPT[M]	RA	Rubber parts, Viton			
M12	M12 X 1[M]	TI	Monel bourdon & socket			
M16	M16 X 1.5[M]	DM	Dampening screw in Monel			
M20	M20 X 1.5[M]	I5	Enclosure protection IP 65			
3B	1/8" BSP[M]	I8	Enclosure protection IP 68			
3N	1/8" NPT[M]	CE	CE marking♦			
4. Execution		DR	MT	Material test certificate**		
DR	Dry		IB	IBR approval#		
FL	Fillable liquid		AP	Anti-parallax mirror band dial##		
LG	Liquid glycerine		HL	Helium leak test		
LS	Liquid silicon	NT	Calibration certificate with NABL traceability			
			VS	Internal vacuum stop		
			Y4	2" pipe/yoke mounting bracket & 'U' clamp SS 304		
			Y6	2" pipe/yoke mounting bracket & 'U' clamp SS 316		
			8. Range			
			Refer range table			
			0-10 Kg/cm²			

Ordering Example: IP-E-1-10B-DR-SG-BY-5C-0-10Kg/cm²

**Material test certificate will be provided for wetted parts only. For others, pls contact factory.
 #For NS 150mm & above. Scale will be marked in Kg/cm² only. For more details contact factory.
 ##For NS 150mm & above.
 ♦For NS 100mm & 150mm only

Note: Specifications and dimensions given in this product catalogue represents the state of engineering at the time of printing. Modifications may take place and materials specified may be replaced by others without prior notice.