

All SS pressure gauge Baffle wall (Solid Front)



Features:

- External zero adjustment (optional)
- Solid Front Design Feature
Baffle wall interposed between the sensing system & the window & a pressure relieving back for increased safety
- Dry / Liquid filled
- Accuracy $\pm 0.5\%$ F.S. (Optional)
- Stainless steel blow-off back

Applications:

- Suitable for high pressure gas
- Corrosive / Hazardous environment that will not obstruct the pressure system

Standard:

- EN 837-1

Standard Parameters

Accuracy	: $\pm 1.0\%$ of F. S.
Ambient temperature	: -20 to $+65^{\circ}\text{C}$
Process temperature	: 300°C max.
Operating Pressure Range	: 75% of the scale value
Over Pressure Limit	: ≤ 100 bar : 125% of Max. Scale Value : > 100 to ≤ 600 bar : 115% of Max. Scale Value : > 600 to ≤ 1600 bar : 110% of Max Scale Value

Materials of Construction

Case & bezel	: AISI 304 SS (Bayonet type)
Bourdon	: AISI 316L SS
Socket	: AISI 316 SS (Directly welded to the case)
Movement	: AISI 304 SS
Joints	: Tig Argon Arc Welding
Protection	: IP 65
Dial	: Aluminium, black graduation on white background
Pointer	: Aluminium, black coloured, micrometer zero adjustable
Window	: Shatterproof / Safety glass
Blow off disc	: AISI 304 SS
Gasket & filling plug	: Neoprene

Glycerine Filled Version

Accuracy	: $\pm 1.6\%$ of F.S.
Ambient Temperature	: Maximum 65°C
Process Temperature	: Maximum 65°C
Window	: Shatterproof / Safety glass
Dampening Liquids	: Glycerine 99.7%

Temperature Effect

The variation of indication caused by effects of temperature is to be calculated by below formula which is to be added in the specific accuracy while measurement:

Formula $\pm 0.04 \times (t_2 - t_1) \%$ of F.S.

where t_1 : reference temperature ($+20^{\circ}\text{C}$) and t_2 : ambient temperature in $^{\circ}\text{C}$.

Dimensional drawing

TYPE 1

TYPE 2

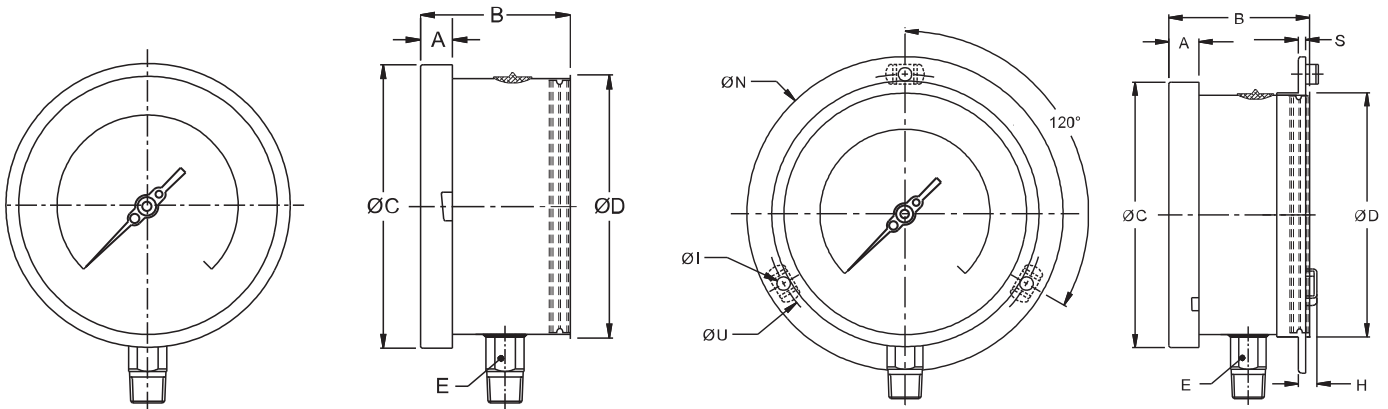

NS	A	B	ØC	ØD	E	W	WG
100	12.5	70	111	100	22	760	1070
150	15	70	161	149	22	1300	2090

W = Weight in grams with box
WG = Weight in grams with glycerine & box

NS	A	B	ØC	ØD	E	ØN	ØU	H	ØI	S	W	WG
100	12.5	70	111	100	22	134	76	15	6	1	860	1170
150	15	70	161	149	22	186	118	15	6	1	1440	2230

W = Weight in grams with box
WG = Weight in grams with glycerine & box

Range table

Note: We offer national & international ranges in Scales like kPa, MPa, bar, psi, kg/cm² & dual Scale like kPa with psi, kPa with bar, bar with psi or scales as per the requirement can be provided on request. Following are the example tables for kg/cm² & psi scales

Single scale (Kg/cm² or bar)

0/0.6	0/4	0/25	0/160	0/1000
0/1	0/6	0/40	0/250	0/1600
0/1.6	0/10	0/60	0/400	
0/2.5	0/16	0/100	0/600	

Dual scale (psi with Kg/cm²)

psi	kg/cm ²	psi	kg/cm ²	psi	kg/cm ²
0/15	0/1	0/400	0/28	0/4000	0/280
0/30	0/2	0/500	0/35	0/5000	0/350
0/60	0/4	0/600	0/40	0/6000	0/400
0/100	0/7	0/1000	0/70	0/10000	0/700
0/150	0/10	0/1500	0/100	0/15000	0/1000
0/220	0/16	0/2200	0/160	0/22000	0/1600
0/300	0/20	0/3000	0/200		

Note: ● Drawings are not to scale ● All dimensions are in mm

Vacuum and Compound Range

Dual scale

inHg with psi	mmHg with kg/cm ²	inHg with psi	mmHg with kg/cm ²	inHg with psi	mmHg with kg/cm ²
- 30/0	- 760 / 0	- 30/60	- 760 / 4	- 30/200	- 760 / 1 4
- 30/15	- 760 / 1	- 30/100	- 760 / 7	- 30/300	- 760 / 2 1
- 30/30	- 760 / 2	- 30/150	- 760 / 10		

Single scale Kg/cm²

- 1/0	-1/1.5	- 1/5	- 1/15
- 1/0.6	-1/3	- 1/9	- 1/24

Accessories

Cooling Tower	Overload Protector (Gauge Saver)	Snubber
Gauge Cock	Needle Valve	Siphon

Ordering codes

1. Dial Size	E	5. Window	SG
Code Nominal size		PG Plexi glass SG Shatterproof/safety glass	
E 100mm	1	6. Options	5C
G 150mm		OA Accuracy ± 0.5% of F.S. (for dry version) S6 AISI 316 SS case & bezel SD AISI 316 SS movement 5C Five -point calibration certificate OS Oxygen service (for dry version) EA External zero adjustment ST SS tag plate DT Dial tag marking CD Custom designed dial OP Over range protection 150% F.S. I5 Enclosure protection IP 65 I8 Enclosure protection IP 68 MT Material test certificate* HL Helium leak test NT Calibration certificate with NABL traceability VS Internal vacuum stop	
2. Mounting	10B	7. Range	0-10 Kg/cm ²
1 Direct bottom 2 Bottom surface		Refer range table	
3. Gauge Connection	DR		
10B 3/8" BSP[M] standard 15B 1/2" BSP [M] standard 15N 1/2" NPT[M] M20 M20 X 1.5[M]			
4. Execution			
DR Dry FL Fillable liquid LG Liquid glycerine LS Liquid silicon			

Ordering Example: BW-E-1-10B-DR-SG-5C-0-10Kg/cm2

*Material test certificate will be provided for wetted parts only. For others, pls contact factory.

Note: Specifications and dimensions given in this product catalogue represents the state of engineering at the time of printing. Modifications may take place and materials specified may be replaced by others without prior notice.